



Datasheet CCT EVO PRO

For more informations visit www.corratec.de

CCT EVO

CCT EVO PRO

Weight from: 7,16 kg

Frame: Corratec CCT Evo

Components: Shimano ULTEGRA Di2

Size: 46, 48, 51, 54, 57, 60

Colors:



TECHNOLOGIES



DESCRIPTION

Secret of Speed

- Brutally stiff
- Superlight
- NACA00038 Profil for super aerodynamics
- ProSize6 System will help you to find the ride size

These characteristics make the CCT Evo to a very super sports machine.

- Electronic shifting with Shimano ULTEGRA Di2.
- Stiff and light Rotor 3D30 crank set.

FRAME

CM	A	B	C	D	E	F	G	H
46	516	119	71	75	974	407	373	518
48	534	130	73	74	973	407	381	534
51	551	144	73	74	978	407	386	550
54	569	153	73	73	991	407	399	558
57	585	178	73	73	1004	407	405	582
60	598	194	73	73	1017	407	413	598

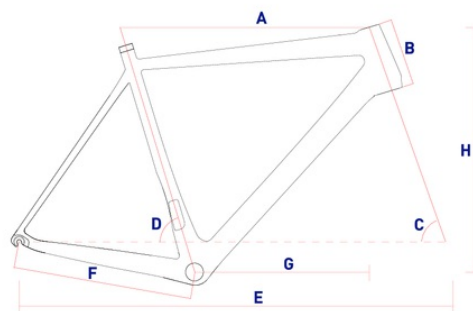

EQUIPMENT

MAIN:

FRAME:	Corratec CCT Evo
FORK:	Corratec Pro Control Fork
BREAKES:	Shimano ULTEGRA Direct Mount front Shimano ULTEGRA Direct Mount rear
STEM:	ZZYZX SL Alloy
HANDLE BAR:	ZZYZX SL Alloy Handlebar
SADDLE:	Fizik Antares R7
SEAT POST:	ZZYZX Twin Bolt

WHEELSET:

RIM:	Mavic Cosmic Elite
TIRE:	Continental Grand Prix 4000S II

DRIVE:

CHAINWHEEL:	Rotor Vegast Spider
CASSETTE:	Shimano ULTEGRA
FRONT DERAILLEUR:	Shimano ULTEGRA Di2
REAR DERAILLEUR:	Shimano ULTEGRA Di2 11s
SHIFT LEVERS:	Shimano ULTEGRA Di2 11s

SPECIAL:

CHAINWHEEL RATIO:	2s; 50/34
CASSETTE RATIO:	11s; 11-12-13-14-15-17-19-21-23-25-28

