



Datenblatt CCT EVO 105

Weitere Informationen finden Sie auf der Homepage www.corratec.de

CCT EVO

CCT EVO 105

Rahmen: Corratec CCT Evo

Komponenten: Shimano 105

Größe: 46, 48, 51, 54, 57, 60

Farben:



TECHNOLOGIEN



LOW PROFILE CHAINSTAY



PRO CONTROL FORK



PRO SIZE SYSTEM



BESCHREIBUNG

- Leichter und steifer **EPS NACA 0038** geformter Toray Carbon Rahmen
- **Pro Control Fork** - Aerodynamisch (NACA 0038) schwingungsdämpfende Carbon Gabel
- **Pro Size 6 System** - Perfekte Rahmen Passform für jeden Fahrertyp
- **Maximaler Vortrieb** - speziell bei steilen Ansteigen und langen Passstraßen

RAHMEN

CM	A	B	C	D	E	F	G	H
46	516	119	71	75	974	407	373	518
48	534	130	73	74	973	407	381	534
51	551	144	73	74	978	407	386	550
54	569	153	73	73	991	407	399	558
57	585	178	73	73	1004	407	405	582
60	598	194	73	73	1017	407	413	598

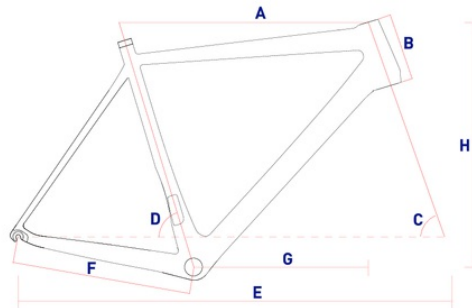

AUSSTATTUNG

BASIS:

RAHMEN:	Corratec CCT Evo
GABEL:	Corratec Pro Control Fork
BREMSEN:	Shimano 105 Direct Mount vorne Shimano 105 Direct Mount hinten
VORBAU:	ZZYX SL Alloy
LENKER:	ZZYX SL Alloy Handlebar
SATTEL:	Corratec SL Race
SATTELSTÜTZE:	ZZYX Twin Bolt

LAUFRAD:

FELGE:	ZZYX SL Alloy Road vorne ZZYX SL Alloy Road hinten
REIFEN:	Continental Grand Prix vorne Continental Grand Prix hinten

ANTRIEB:

KURBEL:	Shimano R7000
KASSETTE:	Shimano ULTEGRA
UMWERFER:	Shimano 105
SCHALTWERK:	Shimano 105 11s
SCHALTABEL:	Shimano 105

SPEZIAL:

ÜBERSETZUNG KURBEL:	2s; 50/34
ÜBERSETZUNG KASSETTE:	11s; 11-12-13-14-15-17-19-22-25-28-32

